

Installation procedure for THERAPEUTIC BATHS

Comfort Air™ - AeroMassage™- Super AeroMassage™
Chromatherapy

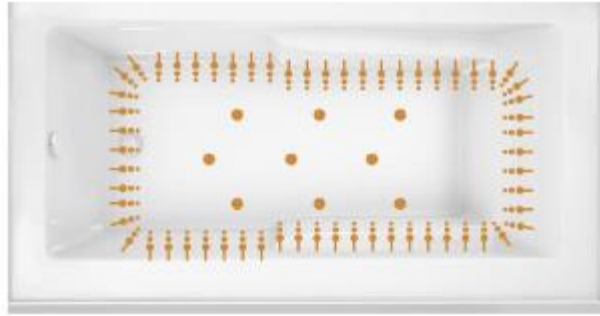

Serial Number : _____

Model Name : _____

Date of Manufacture : _____

- For Warranty, please refer to our website: <http://www.oceania-attitude.com>
3/22/22

IMPORTANT SAFETY INSTRUCTIONS: CAREFULLY READ AND FOLLOW **ALL INSTRUCTIONS PRIOR TO INSTALLING THE UNIT**

WARNING: When using this unit, basic precautions should always be followed, including the following:

- **DANGER:** To reduce the risk of injury or drowning, do not permit children to use this unit unless they are closely supervised at all times.
- Use this unit only for its intended use as described in this manual. Do not use attachments not recommended by the manufacturer.
- Never drop or insert any object into any opening.
- **WARNING:** To avoid injury, exercise care when entering and exiting your bathtub.
- **WARNING:** Risk of accidental injury, or drowning; do not use alcohol, drugs or medication before or during the use of the bathtub.
- **WARNING:** Risk of electric shock; do not allow electric appliances such as hair dryer, lamp, telephone, radio or television within 1.5 meter (5 feet) of this bathtub.
- **WARNING:** Risk of hyperthermia and possible drowning; Water temperature in excess of 38°C may be injurious to your health. Check and adjust water temperature before use.

- If you suffer from headache, dizziness or nausea, get out of the bath and take a cool shower. The water in your bath could be too hot and you may be suffering from hyperthermia. If this problem persists, consult your doctor.
- Inappropriate use of essential oils, at full strength, may cause skin irritation and could damage the bath surface.
- **WARNING:** Some brands of *Wintergreen* essential oils have been known to damage acrylic surfaces.

RULES FOR THERAPEUTIC AIR BATHS

- The unit must be connected only to a supply circuit that is protected by a ground-fault circuit-interrupter (GFCI). Such a GFCI should be provided by the installer and should be tested on a routine basis. To test the GFCI, push the test button. The GFCI should interrupt power. Push the reset button. Power should be restored. If the GFCI fails to operate in this manner, there is a ground current flowing, indicating the possibility of an electric shock. Do not use this unit. Disconnect the unit and have the problem corrected by a qualified service representative before using.
- **WARNING:** Risk of accidental injury or drowning; do not use system bathtub unless all suction guards are installed to prevent body and hair entrapment. Even when the guards are in place, take special attention to long hair, which could be sucked up into the system. ***NEVER WASH YOUR HAIR WHILE THE SYSTEM IS RUNNING.***
- The use of a therapeutic air bath for the first time may cause an uncomfortable feeling. Limit your bathing time to 5 or 10 minutes for the first few baths, afterwards, progressively prolong your bathing time.
- Never start the therapeutic system if the jets are not completely submerged.
- Building materials and wiring should be routed away from the pump or blower body or other heat-producing components of the unit.

INSTALLATION INSTRUCTIONS

The services of a professional plumber and of an electrician are required for the installation of the bathtub and to hook up the therapeutic air system.

1. The minimum structural strength required to support the unit is 1200 lbs, 545 kg (tub and water).
2. To avoid vibration problems, leave a small space of 1/16" between the podium (deck) and the bath lip, seal that space with silicone.
3. For units with tile flange, leave a small space of 1/8" between the bath lip and the tiles on the walls, seal that space with silicone.
4. The tub must be solidly supported at its base and leveled. **It should not be suspended by the bath lip.**
5. For units with one or many sided skirts, the bathtub must be entirely supported by the wooden feet or by the leveling legs. **The skirt(s) should not touch the floor. Leave a small space of 1/8" between the skirt(s) and the floor.** Seal that space with silicone.
6. Prepare the location of the tub, ensuring that all necessary connections (electrical and plumbing) are in place.
7. Check that the tub drain works normally as it should.
8. The bathtub must be properly cleaned of all installation debris before filling it up with water.
9. Before the final bathtub installation, check if the drip water is effected properly.

FOR THERAPEUTIC AIR BATHS

10. **Never** use a therapeutic air bathtub before final installation (including electrical wiring installation).
11. You must provide a space to let air go through, like a metal grid, to assure fresh airflow to the blower. This will avoid overheating problems. The warranty does not cover the costs for the replacement of a blower that overheated.
12. The free air space in the podium (deck) shall be minimum 13.31 cubic feet and is determined by multiplying the outside length (L), the width (W), and the height (H) (1 inch below the overflow) minus the maximum water capacity in cubic feet (1 inch below the overflow). Tip: 7.48 gallons US = 1 cubic ft.
13. Before finishing the installation of the tub, fill it and check for leaks in the pipe system (which may be caused by transportation, manipulation and/or installation) while it is still accessible.
14. Before closing the podium (deck), make sure that the blower and/or pump are working to ensure that the electrical connections are installed correctly.
15. The blower must be supplied with warm surrounding air and not with cold outside air. The blower should not be installed in a cool space where the temperature could drop below 68 F (20 °C).
16. Ensure that pump, blower and electronic control are accessible for future maintenance. An access panel of at least one square foot must be included in your deck plans. **No repair under warranty will be made if no access panel is available.**

NOTE: All repairs, if needed, should be done by a factory approved repairman. No periodic maintenance is required for the pumps, blowers or keypads.

17. Never handle your bathtub by the piping. Do not rest your bath on the jets or pipes located underneath the bath. Be careful not to hit a wall, the deck or doorframe with the jets or pipes installed on the bath.
18. Before finishing the installation, **be certain to clean the space under and around the bath** to avoid the suction of debris by the blower inside the system.

Before finalizing the installation, it is important to test that the bathtub drains properly. Check that there is no water on the bath edges and in the bottom of the bathtub. NOTE: It is normal that a few small puddles remain. If the test is not done, this will invalidate the warranty.

INSTALLATION ON DECK :

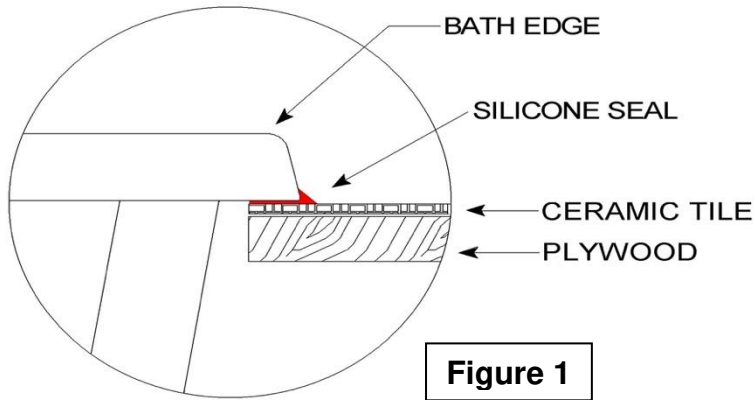

INSTALLATION AGAINST A WALL

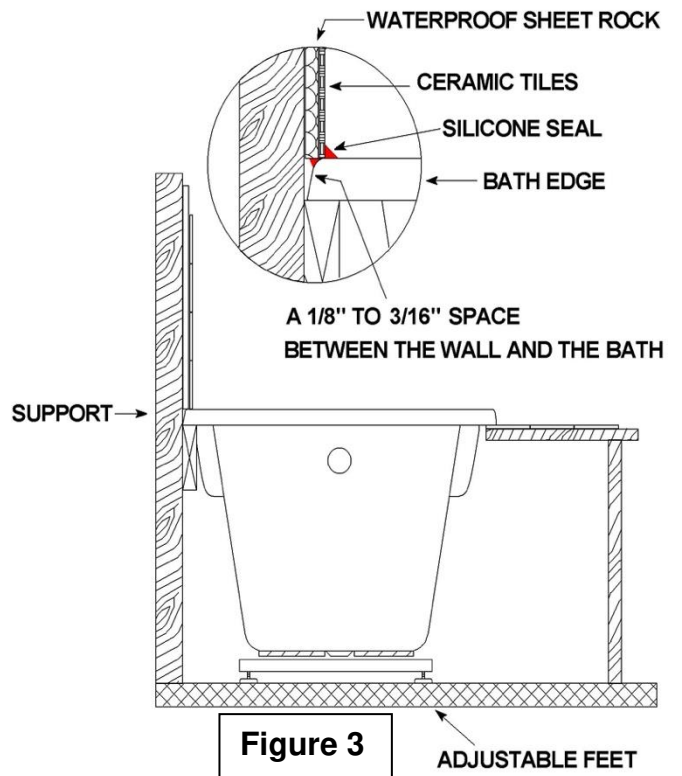

INSTALLATION WITHOUT ADJUSTABLE FEET :

LEVEL WITH WOOD SHIMS

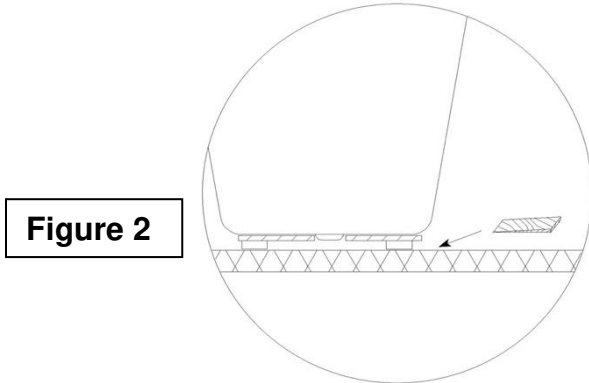

INSTALLATION AGAINST A WALL WITH TILE FLANGE :

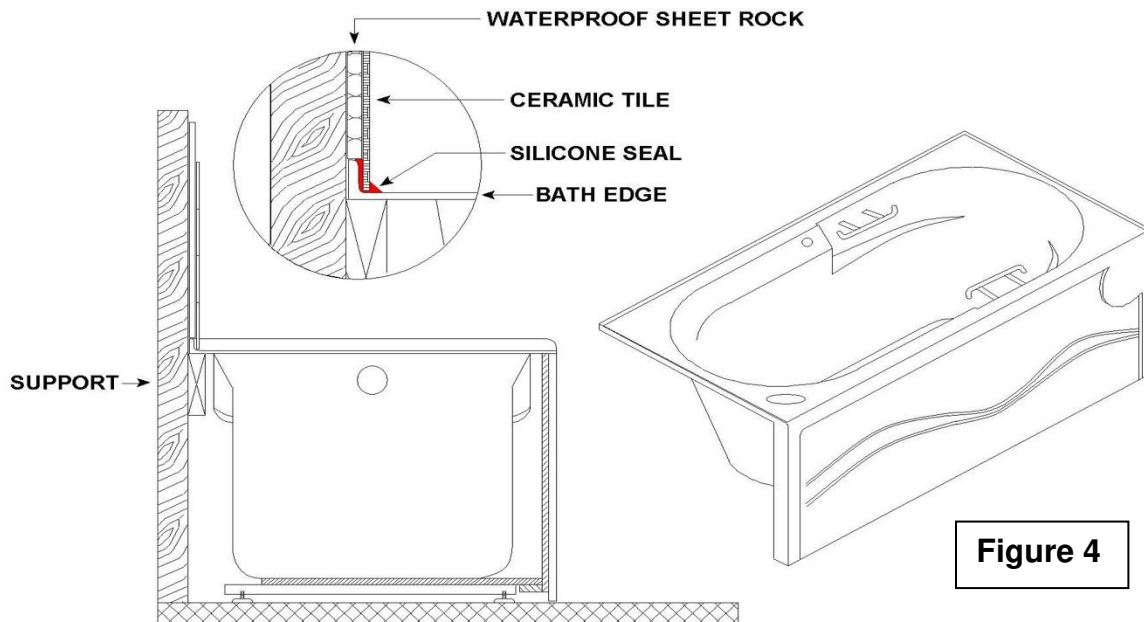

TWO PIECES FREESTANDING BATH INSTALLATION:

1. Place bath in its final position and adjust leveling legs to make it leveled in both directions. Draw a reference line on the floor (around the skirt).

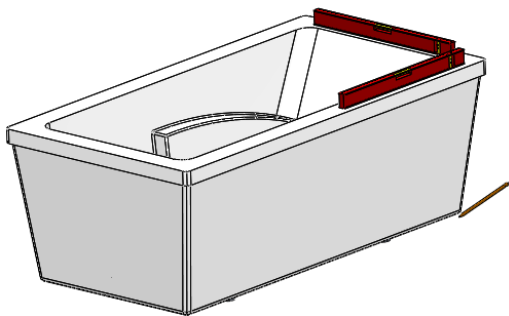

2. Flip the bath, remove the screws that hold the skirt to the bathtub and remove the skirt.

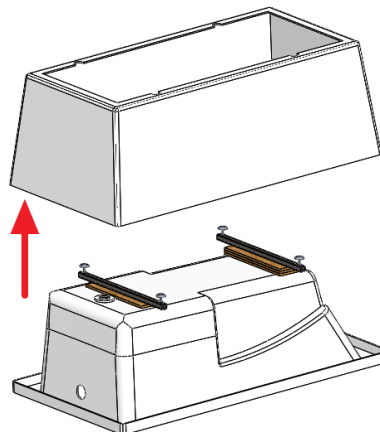

3. Install faucet, drain and overflow. Use flexible hoses for hot and cold water supply. Make sure the overflow is narrow enough to fit between the bath and the skirt.

Connect bath drain into the floor drain without any glue to make sure the installation is appropriate. Draw a mark around each of the 4 legs.

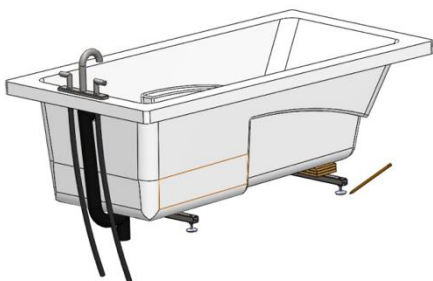

4. Flip the bath upside down on blocks and re-install the skirt with the screws removed in step 2.

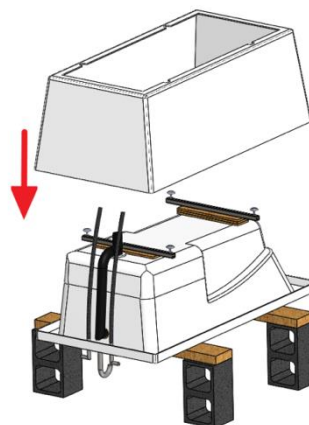

5. Flip the bath/skirt assembly on the blocks. Make required connections (hot/cold water, chromatherapy light, keypad, water detector, blower). For certain models, the blower should be installed somewhere else than under the skirt to allow an easy access to it.

Test water supply connections and test drain to make sure there is no leakage. After testing, use a small container to collect water under the bath.

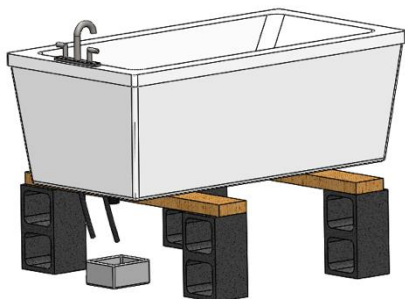

6. Apply a fair amount of silicone on the floor, onto the 4 spots marked in step 3 (4 legs).

7. Remove the blocks and put down the bath in its final position while connecting the drain.

Note : To lift the bath in the future, remove the drain and overflow from inside the bath and lift the bath/skirt assembly.

ELECTRICAL INSTALLATION

WARNING: When using electrical products, basic precautions should always be followed, including the following:

- a) For Indoor use only.
- b) Install in accordance to Oceania Baths installation instruction.
- c) Use supply wires suitable for minimum 90°C.
- d) Use copper conductors only.
- e) **DANGER: RISK OF ELECTRIC SHOCK.** Connect only to a circuit protected by a ground-fault circuit-interrupter (GFCI) of Class A.
- f) Grounding is required. The unit should be installed by a qualified service representative and grounded.
- g) For all units, install to allow access for servicing.

NOTE: In some areas, local regulations may require that professionals carry out the electrical installation. For your own safety, respect these regulations.

1. Before starting the electrical installation, turn off all power supply.
2. The circuit should be connected permanently to the electrical panel. Never use an extension wire. The electrical installation must be permanent and in accordance with local regulations.
3. Each system of your bath (pump and blower) must be connected to an independent 15 amp, 120V electrical power supply protected by a ground fault circuit interrupter (GFCI) of no more than 15 amp, supplied by the electrician installing your bath. Regularly check the GFCI circuit breaker to be certain that it always works properly.
4. In order to reduce the risk of electrocution, all surrounding electrical installations must be properly grounded.
5. An equipment grounding terminal is provided in the field wiring compartment. To reduce the risk of electric shock, this terminal must be connected to the grounding means provided in the electric supply panel with a conductor equivalent in size to the circuit conductors supplying this equipment.
6. (For units in Canada) Install this unit in accordance with the Canadian electrical code, Part 1.
7. No wall timer is necessary with all of our systems; every system is equipped with an integrated 20-minute timer.

ELECTRICAL WIRING DIAGRAMS

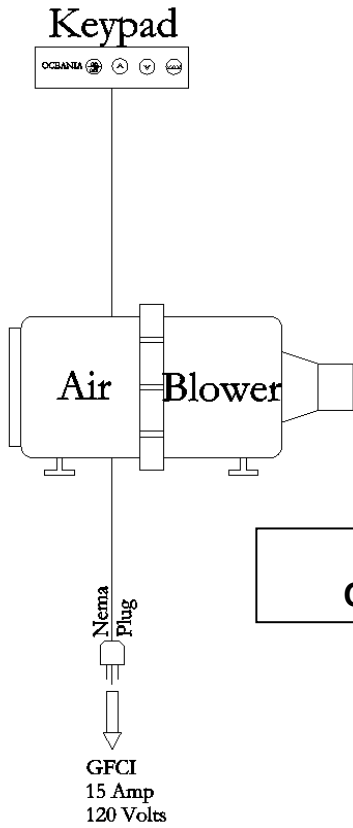

**Figure 5
Comfort Air™**

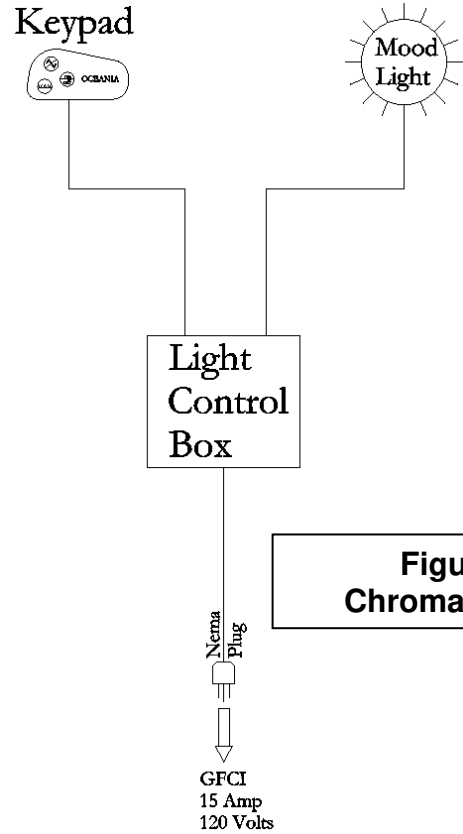

**Figure 6
Chromatherapy**

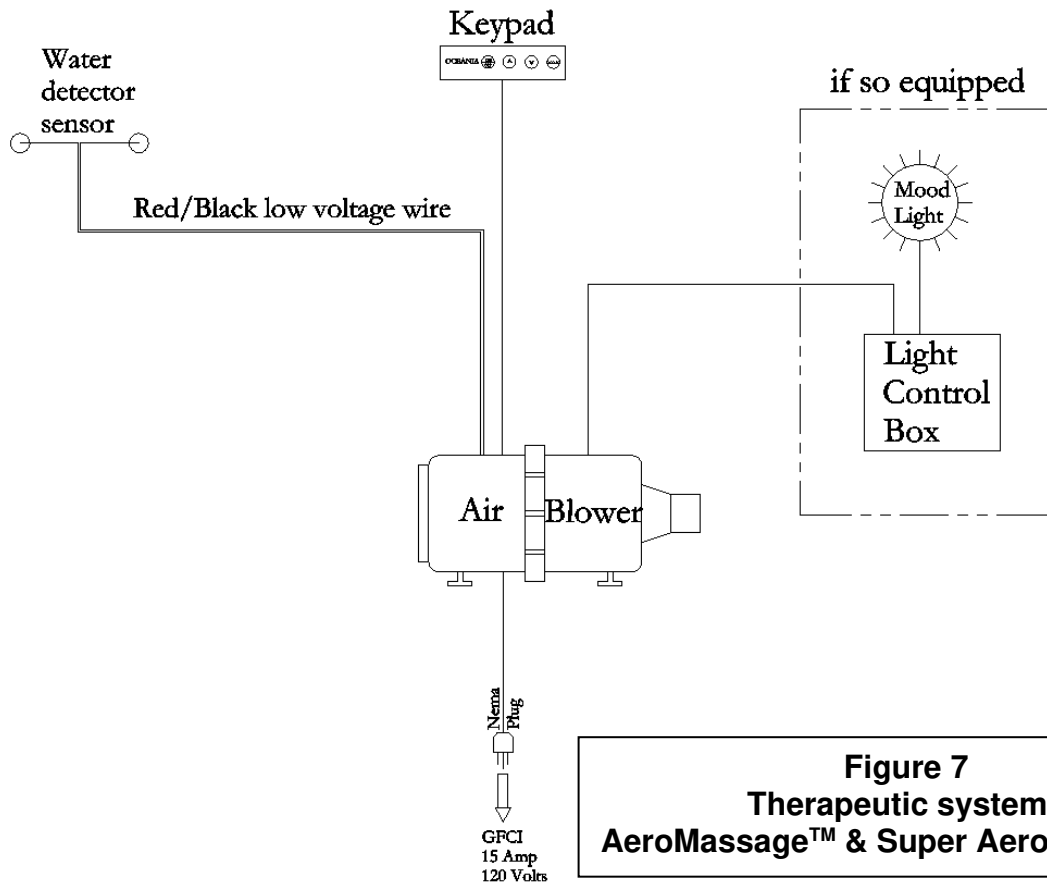

**Figure 7
Therapeutic systems
AeroMassage™ & Super AeroMassage™**

AEROMASSAGE AND SUPER AEROMASSAGE SYSTEMS INSTALLATION INSTRUCTIONS ON CLAW-FOOT BATHS

1. Slide down the retention ring (H) and the bell flange (G) onto the main air pipe (F).
2. Slide down the seal flange (N) (with flange lips facing down) onto the main air pipe (F).
3. Slide down the seal (O) (with rubber facing up) onto the main air pipe (F).
4. Push wires (D & L) into the main air pipe (F).
5. Push wires (D & L) through the floor (I). Glue in the ABS quick coupler (J) to the ABS elbow (M). Run wires (D & L) through the ABS quick coupler (J) and through the hole positioned on the side of the ABS elbow (M) and then through the rubber grommet (E).
6. Fit the main air pipe (F) into the main air pipe adapter (P) located underneath the bath deck. Carefully guide the wires (D & L) into the grooves on top of the main air pipe (F) to avoid any damage.

Should future maintenance be required, it is recommended to leave access to the plumbing and ABS connections

7. Place the main air pipe retention ring (H) at floor level and tighten. Slide down the bell flange (G).
8. Fit the ABS quick coupler (J) onto the main air pipe (F) and firmly tighten. Connect the ABS pipe and the wires (D & L) to the blower.
9. Slide the seal (O) and the seal flange (N) up to the main air pipe adaptor (P) and bolt in place with the included bolt.
10. Push the rubber grommet (E) back into place and leave the excess wire in the floor and fill the grommet with silicone (**VERY IMPORTANT**: silicone must be completely dry before the blower is turned on).

	Description of Components
A)	Bath deck
B)	Electronic control keypad
C)	Keypad plug
D)	Keypad wire
E)	Rubber grommet
F)	Main air pipe
G)	Bell flange
H)	Retention ring
I)	Floor
J)	ABS quick coupler
K)	Air channel
L)	Water detector wire
M)	ABS elbow
N)	Seal Flange
O)	Seal
P)	Main Air pipe adapter

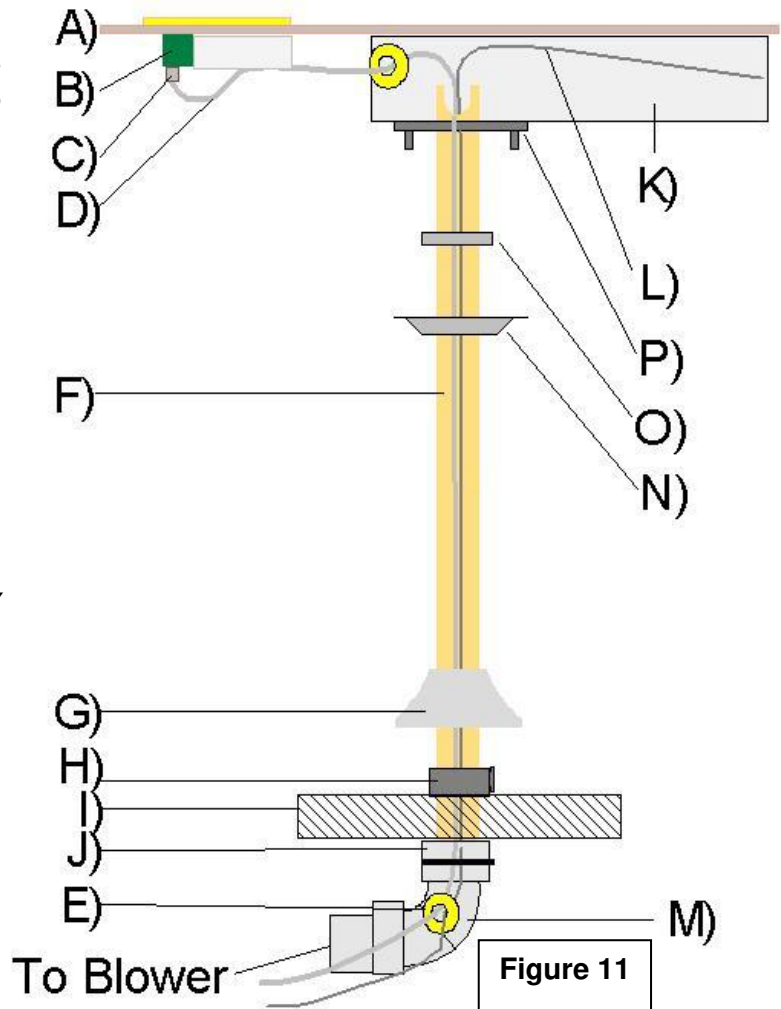

How to Use the Therapeutic Air System

1. The massage provided by the Therapeutic Air System depends on the number of tiny air bubbles running over your skin. The more bubbles you have, the more you feel the intensity of the massage penetrating deeply into your muscles.
2. The tub must be properly cleaned before use.
3. Your bathtub is equipped with a variable speed blower and an electronic control.
4. Fill your therapeutic air bath at least to submerge the holes on the side of your bathtub. There is no risk to damage the air blower but it will prevent water from being splashed.
5. The therapeutic air system comes with an automatic cleaning feature that completely dries all pipes and channels and guarantees optimal hygiene (see "*How the Drying Cycle Works*" section on this page for more details).
6. The blower can be relocated up to 12 feet from the bath. Ask your dealer for more information on blower relocation. Please note that it is normal to hear the blower working.
7. All of our blowers are equipped with an integrated thermal protection that may turn off the blower, if the internal blower temperature is too hot. Wait for at least 30 minutes before using the system again

How the Drying Cycle Works

Your new bathtub equipped with a therapeutic or combo system is also equipped with a sophisticated sanitizing/drying cycle that assures you the highest level of hygiene for your bathtub system components. In the following points, discover how this sanitizing/drying system works.

- a) The sanitizing/drying cycle automatically starts the blower for about two minutes during which hot air is blown through the air system, drying the entire air system. Let this automatic cycle complete this sanitizing/drying phase. Do not manually shut off this cycle, it will automatically start again 13 minutes later.
- b) The electronic control of your system is designed to start an automatic sanitizing/drying cycle 13 minutes after the blower has been turned off.
- c) The electronic control of your system is also designed to start an automatic sanitizing/drying cycle 40 minutes after water is detected in the bathtub and the keypad was not used. For example, if you take a 15 minutes bath (without using the system), the sanitizing/drying cycle will start 25 minutes after the bath, which is 40 minutes after water detection. The sanitizing/drying cycle will start over every 40 minutes until the bathtub system pipes are completely dry.
- d) After the purge, the electronic control verifies to make certain that the air system is dry. If any humidity is detected the 2 minutes sanitizing/drying cycle will repeat later on.
- e) The purge cycle may start for no apparent reason: It is normal for the sanitizing/drying cycle to occasionally start on its own, even if you haven't used the bathtub for hours, even days. This is due to a high humidity detected in the system of your bathtub. To ensure maximum hygiene, the electronic control is designed to detect excessive humidity and start the sanitize/dry cycle automatically.

MAINTENANCE

1. The acrylic of your new bathtub has a glossy finish. In order to preserve this finish, never use abrasive cleaners containing scouring powder (ex. Ajax, Vim, etc), steel wool, acetone (nail polish remover), dry cleaning fluid, window-cleaning products, and ammonia compound, paint thinner, mineral or benzene oil on the acrylic surface, the jets and the handles of your bath.
2. Clean your bath once a week using a soft sponge or cloth with a liquid detergent (ex. Fantastik Original, Hertel, Simple Green, Greased Lightning, Mr Clean, etc.) and warm water. Make certain the product is recommended for use on acrylic by the manufacturer (see product label).
3. Remove grease, oil, paint or ink stains using isopropyl alcohol. Rinse well and dry using a soft, clean cloth.
4. Mineral deposits and soap films can develop on your bathtub accessories. Regular cleaning is recommended, using mild liquid soap and, if needed, a Teflon scrubbing pad.
5. For small scratches or deeper scratches, and/or any other considerable break, please contact us for advice on how to proceed and/or an acrylic repair specialist referral.
6. You may use bubble baths, bath salts and bath oils just like in an ordinary bathtub, but in smaller amounts, without causing any damage to the pump, the blower or the piping system. The therapeutic effect, combined with a bubble bath, may cause excessive bath foam. Use less of any foaming agent when taking a therapeutic or hydromassage bath.
7. After using bath salts and/or oils, you need to refill your bath up to 2" above the highest jet with cold water, and start the system(s) for 2 or 3 minutes in order to rinse all residues that may still be inside the system.
8. Disinfect your bath every month or after a long period of non-use of the bath system, by following these instructions:
 - a) NEVER START THE SYSTEM IF THE JETS ARE NOT COMPLETELY COVERED WITH WATER.
 - b) Fill your bath with hot water 2" above the highest jet.
 - c) Add 2 or 3 tablespoons of powder or liquid dishwasher detergent and a maximum of 4 ounces of household bleach directly in the water (CAUTION: too much bleach could cause stains or dulled spots on the surface of the bathtub):

-For therapeutic air system: Start the system for 30 seconds and then stop it for 30 seconds. Repeat this cycle ten times.
 - d) Empty your bath and fill it again using cold water, and as always, 2" above the highest jet.

For therapeutic air system: Start the system for 30 seconds and then stop it for 30 seconds. Repeat this cycle five to ten times.
 - e) Empty your bath and wipe dry.

TROUBLESHOOTING YOUR THERAPEUTIC AIR SYSTEM

Blower fails to operate:

1. Check electric power supply. Reset the circuit breaker or replace the fuse if necessary.
2. Verify that the electronic keypad is properly connected.
3. Check the ground fault circuit interrupter. Reset it if tripped.
4. If the system has been running for a long period, it is possible that the integrated thermal protection has turned off the blower. Wait for at least 30 minutes before using the system again.
5. You must provide a one square foot (minimum) air vent that will let air go through, like a metal grid, to assure a fresh airflow to the blower.
6. The free air space in the podium (deck) shall be minimum 13.31 cubic feet and is determined by multiplying the outside length (L), the width (W), and the height (H) (1 inch below the overflow) minus the maximum water capacity in cubic feet (1 inch below the overflow). Tip: 7.48 gallons US = 1 cubic ft.

Motor runs but no air comes out of the jets:

1. Verify that main air pipe from manifold to blower is properly connected. If necessary, reconnect it and tighten the screw.
2. The air intake is blocked with debris.
3. No air intake panel was installed and not enough air is available for the blower. Install an air intake panel.

The air heater does not seem to be working:

1. If your tub is installed against two outside walls, it is recommended to adequately insulate these outside walls to minimize heat loss.
2. The blower must be supplied with warm surrounding air and not with cold outside air. The blower should not be installed in a space where room temperature could drop under 68 F (20 °C).
3. People with sensitive skin might experience a *cold air effect*, caused by the tiny air bubbles running over their wet skin, causing the bather to shiver. Please note, when the system is started, the blower uses the warm surrounding air; after a few seconds, the heating element, heats this room temperature air and should eliminate the cold air sensation.
4. You can check if the air injected into the bath is hot by touching the black air pipe under the bath.

WARNING : Never take a bath with water temperature over 38°C (100F). If you take very hot baths, the air injected into the bath may seem cool. This cool sensation is caused by the difference of the warm air temperature and the hot skin temperature. The hotter the water, the cooler the air will seem.

The air heater is not designed to heat nor cool the water in the bathtub, it's designed to heat the air injected into the bath, to a temperature near your normal body temperature.

The blower starts on its own:

1. Your bathtub is equipped with a sophisticated sanitizing/drying system that assures you the highest level of hygiene. The electronic control of your system is designed to start an automatic sanitizing/drying cycle 13 minutes after the blower has stopped or 40 minutes after water detection in your bathtub. For about two minutes, hot air is blown through the system. Let this automatic cycle complete the drying phase. Do not manually turn off this cycle; it will start again 13 minutes later. ***Refer to "How the Drying Cycle Works" in the Operation section of this manual on page 17.***
2. **The purge cycle may start for no apparent reason:** It is normal for the sanitizing/drying cycle to occasionally start on its own, even if you haven't used the bathtub for hours, even days. This is due to a high humidity detected in the system of your bathtub. To ensure maximum hygiene, the purge cycle is designed to detect excessive humidity and start the sanitize/dry cycle automatically.