

Installing a keypad

1. Choose the location you wish to install your keypad. The keypad must be installed on a flat surface that is at least 5" long by 1 1/2" wide. Be careful when choosing your location so that there are no wires or pipes that can be cut or pierced.
2. Cover the surface to be drilled with masking tape. (At least 6" by 2")
3. Drill two 7/8" holes 3 1/8" apart.
4. Cut out the excess material between the two holes with a fine tooth saw or a jigsaw.
5. Apply silicone to the underside of the keypad and insert the keypad into the opening.
6. Protect the keypad with a piece of wood when clapping the keypad in place. Let dry for at least 24 hours.
7. Plug in the keypad wire and test that all the buttons are working.

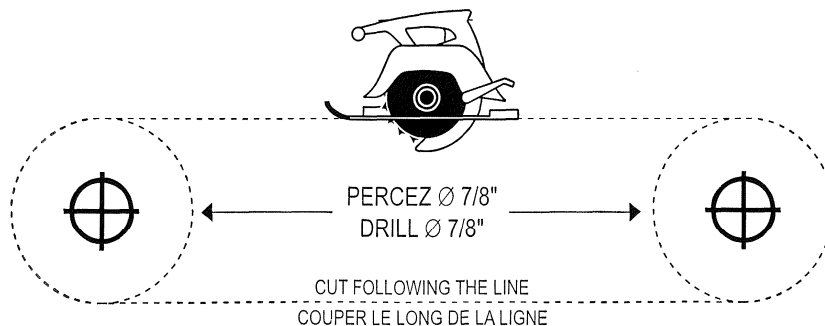

Please note that not all printers will print to scale.