

Installation Procedure for SHOWER BASES

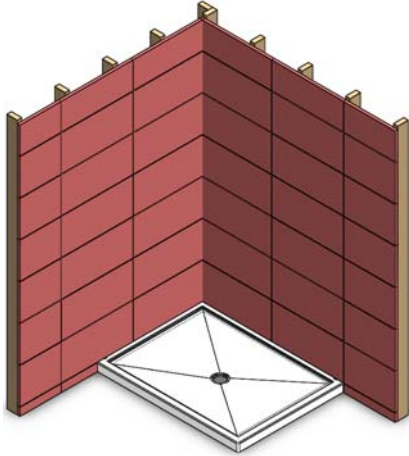

Serial Number : _____

Model Name: _____

Date of Manufacture _____

-For Warranty, please refer to our website: <http://www.oceania-attitude.com>

-The structure supporting your shower base must hold a minimum of 600 pounds (273 kg).

-This Guide is for a leveled floor. If the floor has more than 1/4 " (6 mm) of level difference or imperfections, level your floor or use concrete to secure the base. **NEVER INSTALL ON A HEATED FLOOR.**

1. The first step is the preparation of the installation surface. All walls and floor must form perfect 90° angles and should all be perfectly leveled. Check the drain position.

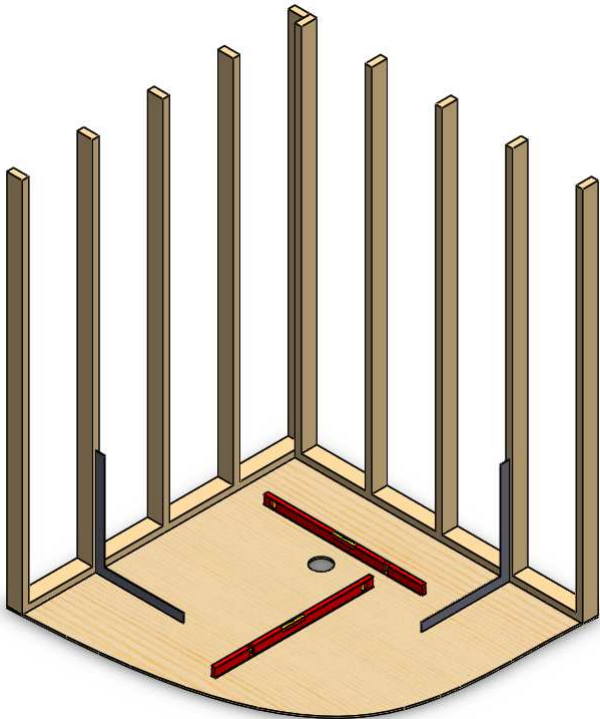

2. Temporarily install your shower base in its final position; use wood shims to ensure it is perfectly leveled. Make sure the shims are placed against rigid parts underneath the base.

Visually inspect your shower base and proceed to a drainage test to ensure that water drains properly.

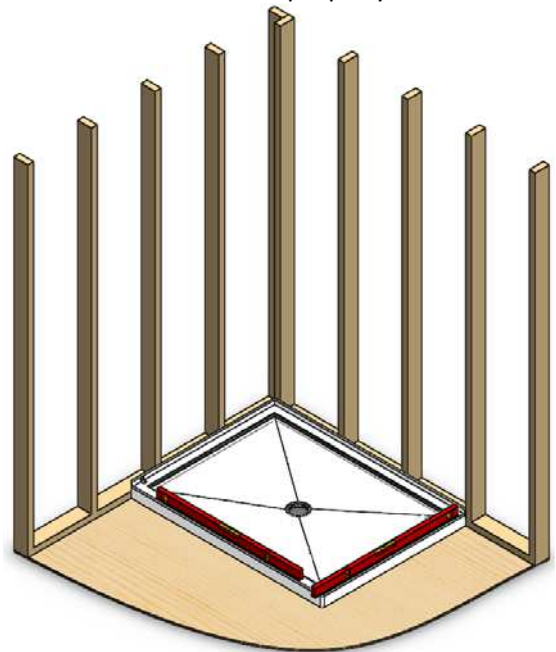

3. Carefully raise the base without moving the shims, which need to remain on the floor. Apply construction adhesive (PL type) on the shims. Install the drain at this step, if needed.

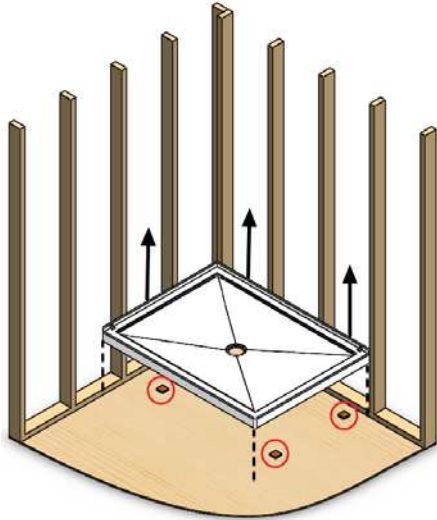

4. Apply construction adhesive (PL type) on all surfaces that will be in contact with the floor.

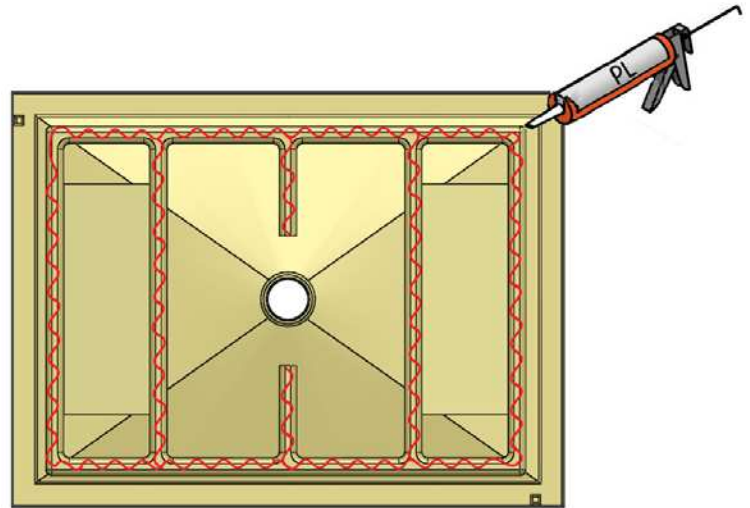

(View from underneath)

5. Reinstall the base in its final position. Slowly push the base to ensure it is sitting on the shims.

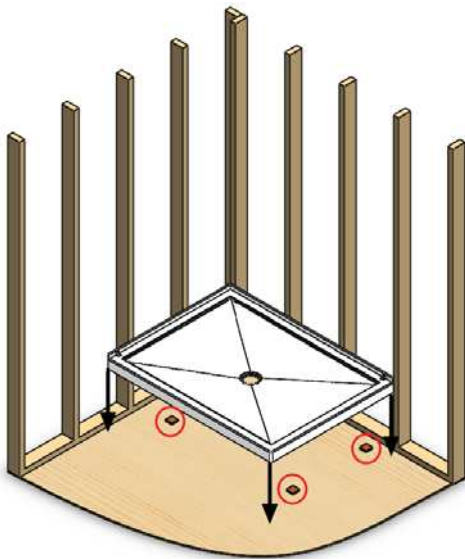

6. Let cure for 24 hours.

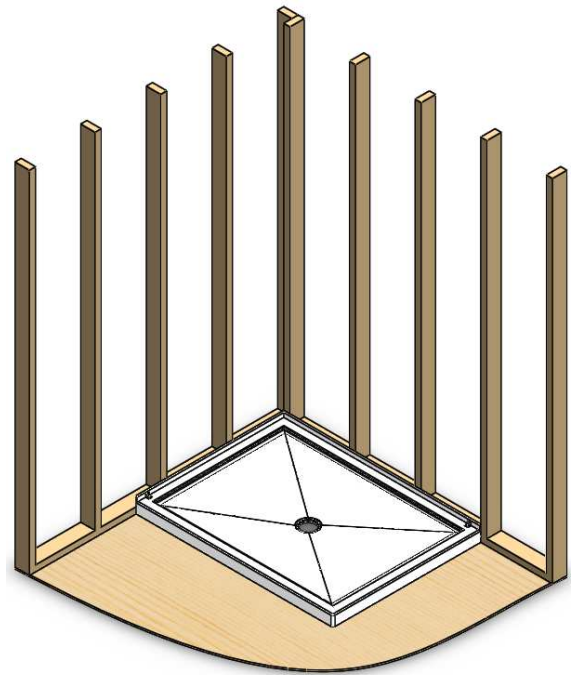

7. Install a waterproof membrane (not provided by Oceania) on the drywall and tiling flange. The membrane must be about 5" (127mm) in contact with the drywall and 1" (25.4mm) with the tiling flange. It is the responsibility of the installer to properly seal the junction between the drywall and the tiling flange.

IMPORTANT: The tile flange **MUST NOT** be screwed to the wall.

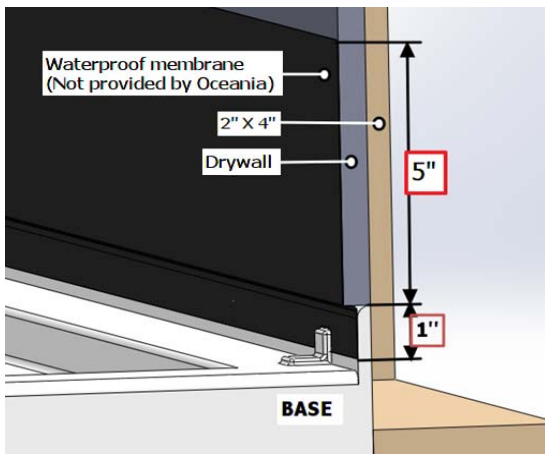
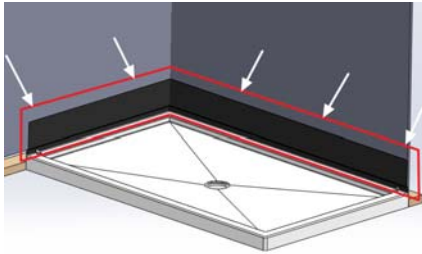

8. Complete the wallcovering. You must lay the ceramic on the seal guard designed for this purpose. Align the ceramic to create a small opening between the ceramic and the base. This opening is approximately 1/8" (3.2 mm).

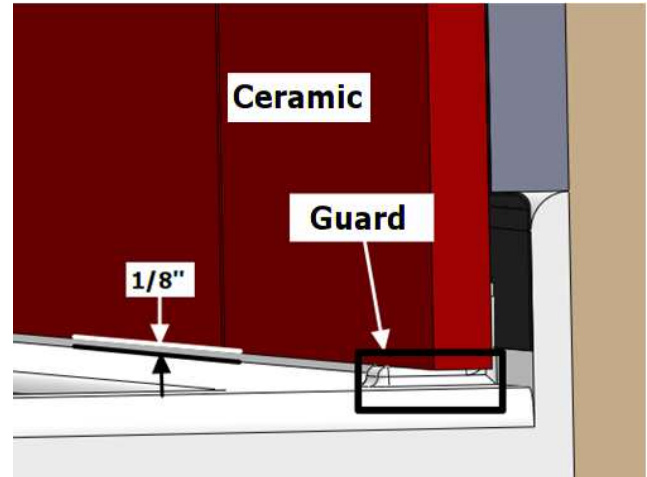

9. Once the ceramic is installed, apply a bead of silicone between the base and the ceramic but leave a minimum opening of 1/2" (12.7 mm) between the inside of the base and seal guard.

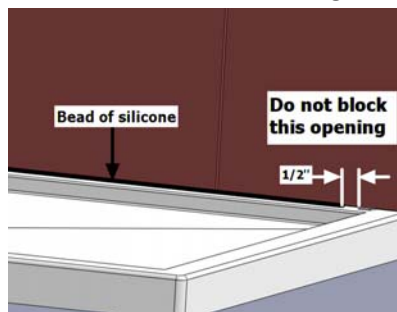

10. Fill the outer portion of the opening with silicone (between the outside of the base and the guard). Make sure that the silicone goes all the way behind the ceramic.

